

# DLP120 Specifications

DLP

ITEMS/UNITS		MODEL	DLP120-24-1
Input	Voltage Range	(*2) V	AC85-132 / 170 - 265 (Auto selectable)
	Frequency	(*2) Hz	47 - 63
	Efficiency (100/230VAC)(typ) (*1)	%	83 / 85
	Current (100/230VAC)(typ) (*1)	A	2.9 / 1.3
	Inrush Current (100/230VAC)(typ) (*3)	A	20 / 45, Ta=25°C, cold start
	Leakage Current	(*9) mA	Less than 0.75
Output	Nominal Voltage	VDC	24
	Maximum Current	A	5
	Maximum Power	W	120
	Maximum Line Regulation(*4)(*5)	mV	120
	Maximum Load Regulation(*4)(*6)	mV	192
	Temperature Coefficient		Less than 0.05%/°C
	Maximum Ripple & Noise (0≤Ta≤60°C)(*4)	mVp-p	240
	Maximum Ripple & Noise (-10≤Ta<0°C)(*4)	mVp-p	360
	Hold-up Time (100/230VAC)(*1)	ms	20 / 30
	Voltage Adjustable Range	VDC	21.6 - 28
Function	Over Current Protection (*7)	A	>5.3
	Over Voltage Protection (*8)	VDC	30.0 - 35.0
	Parallel Operation		-
	Series Operation		Possible
Environment	Operating Temperature (*10)	°C	- 10 to + 60 Convection: -10 to +50 (100%); 60 (60%)
	Storage Temperature	°C	- 30 to +85
	Operating Humidity	%RH	30 - 90 (No dewdrop)
	Storage Humidity	%RH	10 - 95 (No dewdrop)
	Vibration		At no operating and with DIN RAIL, 10-55Hz (sweep for 1min) 9.8m/s <sup>2</sup> constant, X, Y, Z each 1hour
	Shock (In package)		Less than 196m/s <sup>2</sup>
Isolation	Withstand Voltage		Input - Output : 3.0kVAC, Input - FG : 2.0kVAC (20mA) for 1min Output - FG : 500VAC (100mA) for 1min.
	Isolation Resistance		More than 100MΩ at Ta=25°C and 70%RH, Output - FG : 500VDC
Standards	Safety Standards		Approved by UL60950-1, CSA C22.2 No.60950, EN60950-1, UL508, CSA C22.2 No.14-M95, EN50178 CATEGORY III (Primary). Built to meet DENAN.
	PFHC		Built to meet IEC61000-3-2
	EMI		Built to meet VCCI-B, FCC-ClassB, EN55011/EN55022-B
	Immunity		Built to meet IEC61000-6-2 (IEC61000-4-2,-3,-4,-5,-6,-8,-11)
Mechanical	Weight (typ)	g	540
	Size (W x H x D)	mm	60x97x110 (Refer to Outline Drawing)

(\*1) At 100/230VAC and maximum output power, Ta=25°C .

(\*2) For cases where conformance to various safety specs (UL, CSA, EN) are required, to be described as 100-120VAC/200-240VAC, 50/60Hz on name plate.

(\*3) Not applicable for the in-rush current to Noise Filter for less than 0.2ms.

(\*4) Please refer to Fig A for measurement of line & load regulation and output ripple voltage. (Measure with JEITA RC-9131 probe.)

(\*5) 85-132VAC/170-265VAC, constant load.

(\*6) No load - full load (maximum power), constant input voltage.

(\*7) Constant current limit with automatic recovery.

Avoid to operate at overload or dead short for more than 30seconds.

(\*8) OVP circuit will shutdown output, manual reset. (Re Power on)

(\*9) Measured by each measuring method of UL, CSA, EN and DENAN (at 60Hz).

(\*10) At standard mounting method, Fig B.

- Load(%) is percent of maximum output load (Item2 and 3), do not exceed derating in both maximum output current and power.

- For standard mounting, refer to derating curve.

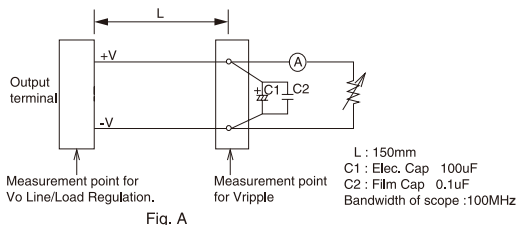

Fig. A

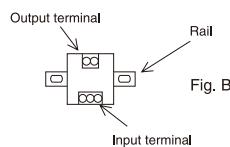

Fig. B

### Recommended EMC Filter



RSEN-2006

Please refer to "TDK-Lambda EMC Filters" catalog.

# Outline Drawing

## [DLP120] (Block Terminal)

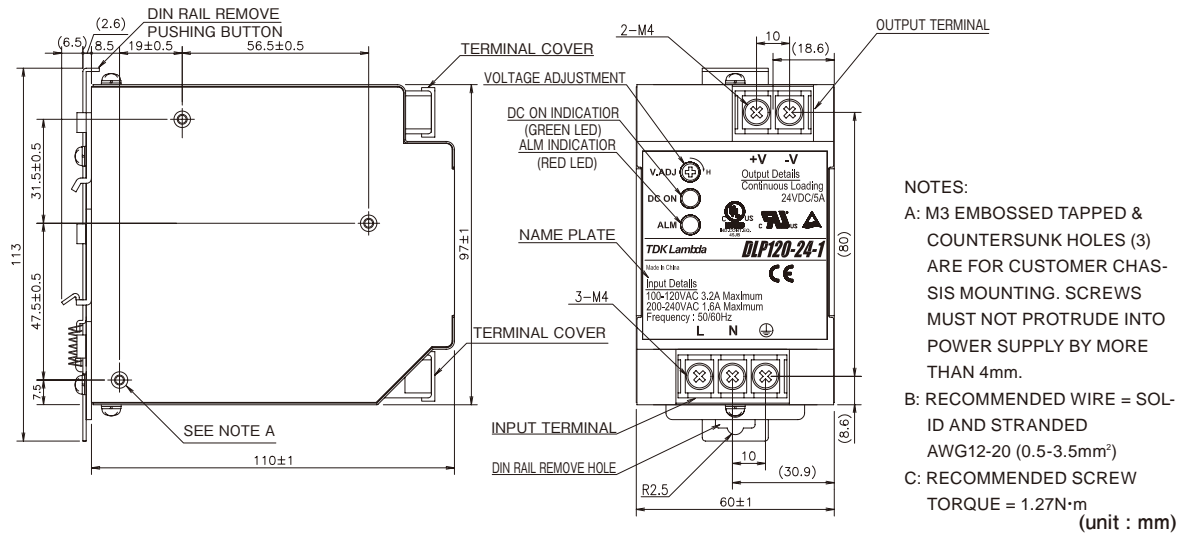

DLP

## [DLP120/EJ] (European Terminal)

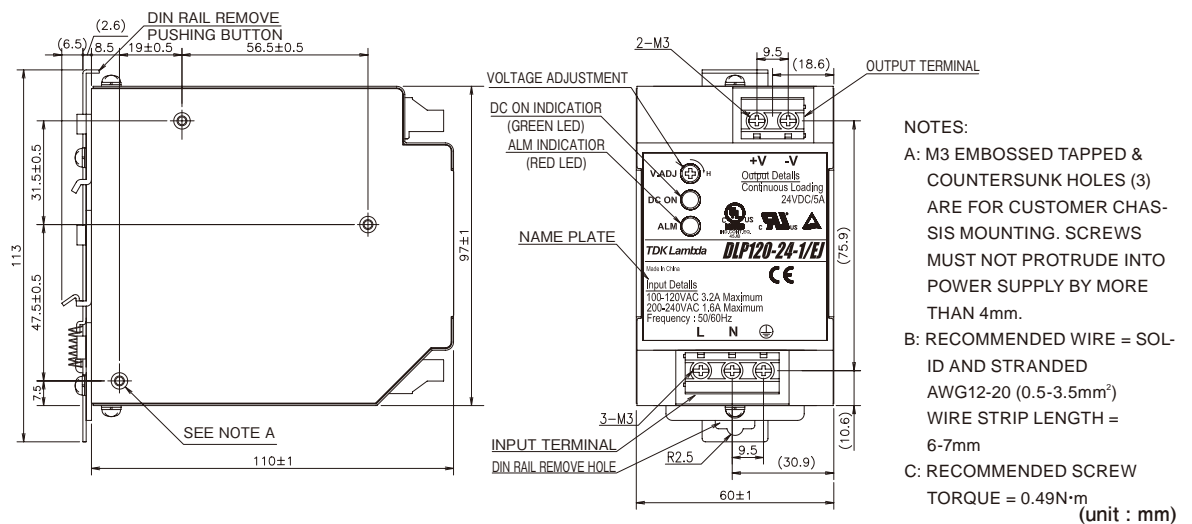

# Output Derating

OUTPUT DERATING CURVE

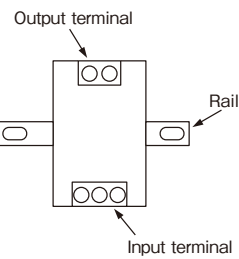
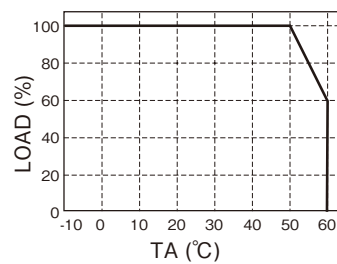

STANDARD MOUNTING