

2. Terminal Explanation

Please pay extra attention to the wiring. Incorrect connection will damage the power supply.

1 Front Panel Explanation

SWS600L

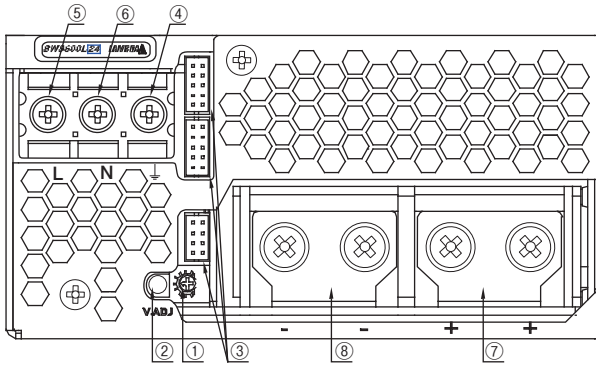

SWS1000L

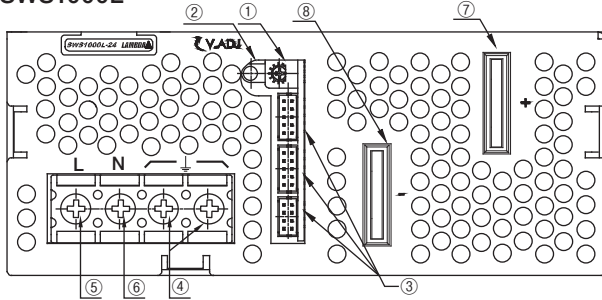

- ① V.ADJ : Output voltage adjustment trimmer.
(The output voltage rises when a trimmer is turned clockwise.)
- ② ON : Output (Power on) indication LED
(The indicator turns on when the power supply output is in normal operating condition.)
- ③ CN1, CN2, CN3 : Remote sensing, ON/OFF control signal, current balance signal, power fail alarm, auxiliary output, output voltage external control signal. (Refer to 1-2.)
- ④ ↓ : Protective earth (Frame ground), M4 screw.
(SWS1000L: M4 screw x 2)
- ⑤ AC input terminal L : Live line (Fuse in line), M4 screw.
- ⑥ AC input terminal N : Neutral line, M4 screw.
- ⑦ + : + Output terminal
(SWS600L: M5 screw x 2 / SWS1000L: φ9hall, M4 tapped hall x 2)
- ⑧ - : - Output terminal
(SWS600L: M5 screw x 2 / SWS1000L: φ9hall, M4 tapped hall x 2)

2 CN1, CN2, CN3 Connector pin Configuration and Function

CN1 and CN2 are same pin configuration and function. They are connected to each other in this power supply unit. When the pin of CN1 side is shorted, the same function pins of CN2 side are also shorted. Please note that the function cannot be separately set with CN1 and CN2.

CN1, CN2	Pin No	Config-uration	Function
	1	+Vm	+OUTPUT VOLTAGE MONITOR
	2	+S	+SENSING
	3	-Vm	-OUTPUT VOLTAGE MONITOR
	4	-S	-SENSING
	5	N.C.	NO CONNECTION
	6	PC	CURRENT BALANCE
	7	PV	ADJUSTMENT OF OUTPUT VOLTAGE
	8	COM	GROUND FOR PC AND PV SIGNAL
	9	CNT2	REMOTE ON/OFF (2)
	10	TOG	GROUND FOR CNT2

CN3	Pin No	Config-uration	Function
	1	COM	GROUND FOR PC AND PV SIGNAL
	2	COM	GROUND FOR PC AND PV SIGNAL
	3	AUX	AUXILIARY OUTPUT (12V 0.1A)
	4	CNT1	REMOTE ON/OFF (1)
	5	G2	GROUND FOR AUX AND CNT1
	6	G2	GROUND FOR AUX AND CNT1
	7	ALM	ALARM
	8	G1	ALARM GROUND

CN1, CN2, CN3 Connector & Housing & Terminal Pin

PART DESCRIPTION	PART NAME	MANUFACT
PIN HEADER	S10B-PHDSS (CN1, CN2) S8B-PHDSS (CN3)	J.S.T
SOCKET HOUSING	PHDR-10VS (CN1, CN2) PHDR-8VS (CN3)	J.S.T
TERMINAL PINS	SPHD-002T-P05 (AWG28~24) SPHD-001T-P05 (AWG26~22)	J.S.T
HAND CRIMPING TOOL	YRS-620 (SPHD-002T-P0.5) YC-610R (SPHD-001T-P0.5)	J.S.T

3. Terminal Connection Method

Please pay extra attention to the wiring. Incorrect connection will damage the power supply.

- When connecting input, output wiring and CN1, CN2, CN3, input AC-Line should be off.
- Input wiring and output wiring shall be separated to improve noise sensibility.
- The protective earth (PE) must be connected to the ↓ terminal or chassis.
- Remote sensing lines shall be twisted or used shielded wires.
- Remote ON/OFF control lines shall be twisted or used shielded wires. Separate from load line.
- Output current of each terminal screw shall be 60A or less for SWS600L.

Panel Side

- Basic connection (Local sensing)
Connect "+S" terminal to "+Vm" terminal and "-S" terminal to "-Vm" terminal.

SWS600L

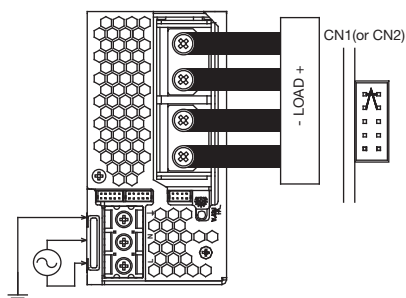

SWS1000L

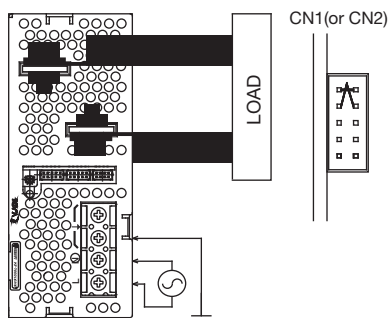

- Remote sensing required
Connect "+S" terminal to "+" terminal of load and "-S" terminal to "-" output terminal of load with wires.

SWS600L

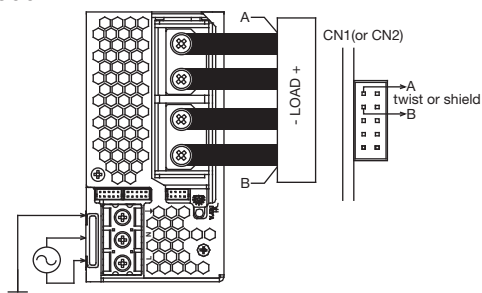

SWS1000L

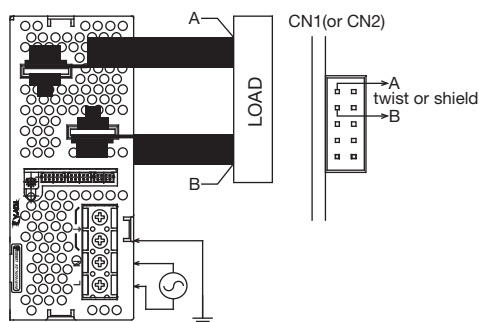

- ALM signal output required
Open collector method shown below shall be used.
"G1" terminal is ground for "ALM" terminal.

SWS600L

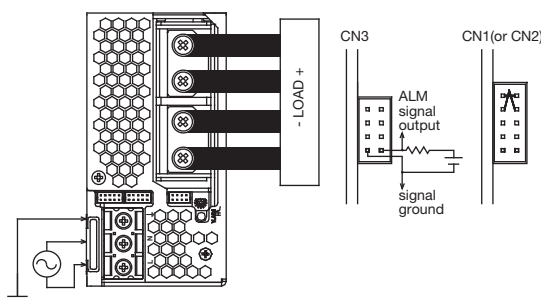

SWS1000L

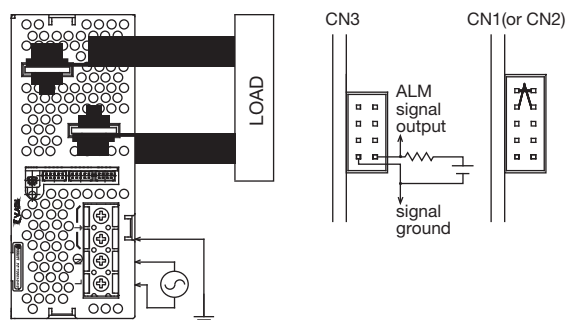

4. Functions and Precautions

1 Input Voltage Range

Input voltage range is single phase 85 - 265VAC (47 - 63Hz) or 120 - 350VDC. Input voltage, which is out of specification, may cause unit damage. Rated input voltage for safety standard application is 100AC-240VAC (50/60Hz).

2 Output Voltage Range

Output voltage is set to the rated value at shipment. V.ADJ trimmer on the front panel side can be used to adjust the output voltage within the range specified (refer to specifications for adjustable range).

To turn the trimmer clockwise, the output voltage will be increased. Take note when the output voltage is increased excessively, over voltage protection (OVP) function may trigger and output voltage will be shut down.

3 Over Voltage Protection (OVP)

The OVP function (inverter shutdown method, manual reset type) is provided. OVP function operates within specified range (refer to specification) of the rated output voltage value and the output will be shut down when OVP function triggers (refer to specifications for OVP range of each models). To reset OVP, remove the input of power supply for a few minutes, and then re-input. Or, use CNT to reset (remote ON/OFF : OFF to ON). OVP value is fixed and not to be adjusted externally. Never apply more than rated output voltage to output terminal, which may lead to damage. In the case of inductive load, use decoupling diode at output line.

4 Over Current Protection (OCP)

The OCP function is provided. OCP characteristic is constant current limiting, automatic recovery. OCP function operates when the output current exceeds 105% (24V output model: 101% of peak current) of maximum DC output current specification. The output will be automatically recovered when the overload condition is cancelled. Never operate the unit under over current or shorted conditions for more than 30 seconds, which may lead to damage. OCP setting is fixed and not to be adjusted externally.

5 Over Temperature Protection (OTP)

The OTP function (manual reset type) is provided. When ambient or internal temperature rises abnormally, OTP function operates and output will be shut down. After shut down, remove the input and cool it down to reset OTP. Then re-input.

6 Power Failure Detection Circuit (ALM)

Power failure detection circuit is provided. ALM (Alarm) signal will turn "High" level to indicate the abnormal status when converter stops. Please take note in parallel or N+1 operation at light load condition, maybe only one of the power supply operates and other power supply stops. When the built-in FAN motor of this power supply unit stops, ALM signal will turn to "High" too. If the output voltage is decreased to less than 20% of rated voltage, or decreased rapidly through an external adjustment mechanism when load is light, the ALM signal may turn "High". The ALM signal is isolated from input and output by a photo-mosfet. It uses the open collector method shown as below.

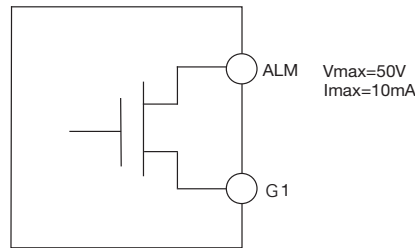

7 Remote Sensing (+S, -S terminal)

This function compensates voltage drop of wiring from output terminals to load terminals. Connect "+S" terminal to "+" terminal of load and "-S" terminal to "-" terminal of load with sensing wires. The total line voltage drop (+ side line and - side line) shall be less than 0.3V. In case that sensing lines are too long, it is necessary to put an electrolytic capacitor in following places.

- (1) across the load terminal,
- (2) between "+S" terminal and "+V" terminal,
- (3) between "-S" terminal and "-V" terminal.

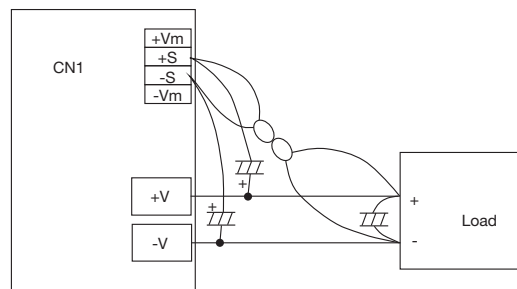

When the function of remote sensing is not used, connect +S terminal to +Vm terminal, and -S terminal to -Vm terminal by the attachment connector.

If remote sensing terminals are opened, the stability and the accuracy of the output deteriorated. Therefore, terminal +S, -S must be connected.

8 Remote ON/OFF Control

Remote ON/OFF control is provided.

Using this function, output on/off is allowed to control without input voltage on/off.

- (1) The maximum input voltage to CNT2 terminal is 12V, and the maximum allowable reverse voltage is -1V; Current flow into CNT2 is 5mA typical and 12mA maximum.
- (2) A switch and relay or a transistor can be used as ON/OFF switch.
- (3) Remote ON/OFF control circuit is isolated from the input and output by a photo-coupler and can be controlled regardless of the output potential (+ or -). Connect TOG terminal to ground of control signal.

Specifications of remote ON/OFF

CNT2-TOG current or voltage condition:

Connection method		(a)	(b)	(c)
SW Logic	Output on	SW open (0.1mA max)	SW open (0.1mA max)	SW close (0.5V max)
	Output off	SW close (3mA min)	SW close (3mA min)	SW open (0.1mA max)
Pin		CNT2, TOG	CNT1, CNT2, TOG, G2	CNT1, CNT2, TOG, G2

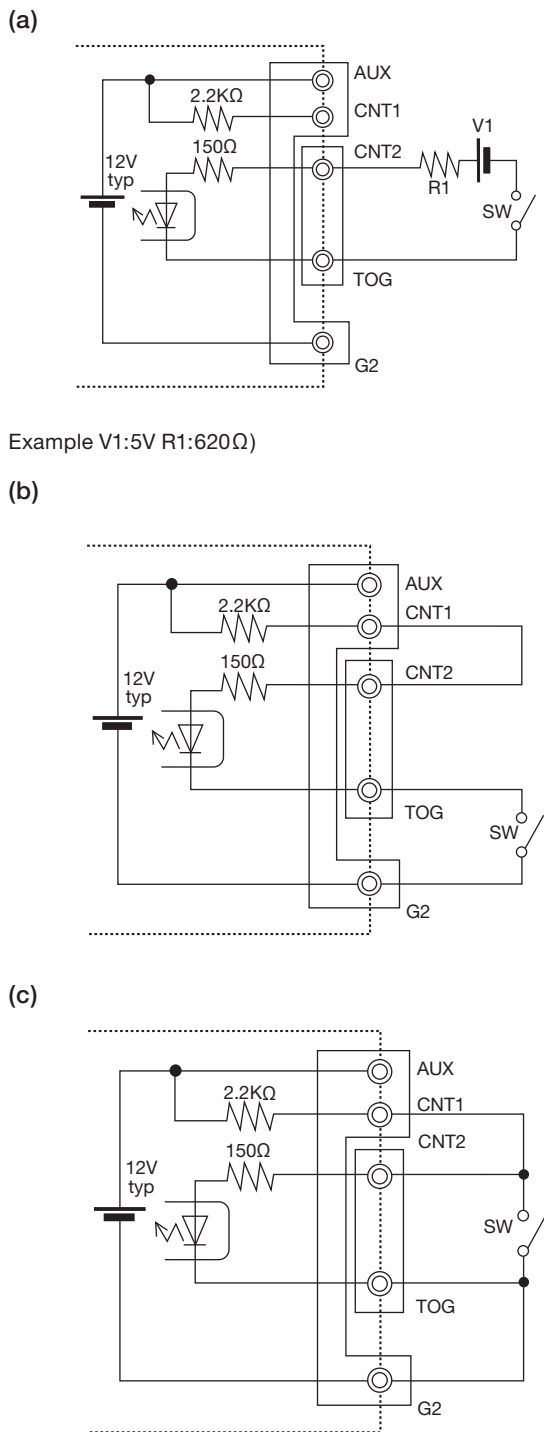
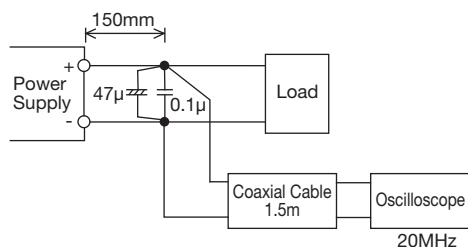

Fig.2.3 Examples of connecting remote ON/OFF circuit

9 Output Ripple & Noise

The standard specification for maximum ripple value is measured by measurement circuit as below. When load lines are longer, ripple becomes larger. In this case, electrolytic capacitor, film capacitor, etc. might be necessary to use across the load terminal. The output ripple cannot be measured accurately if the probe ground lead of oscilloscope is too long.



• All specifications are subject to change without notice.

10 Series Operation

For series operation, both method (A) and (B) are possible. There might be a step in the output rise waveform during series operation.

Method (A)

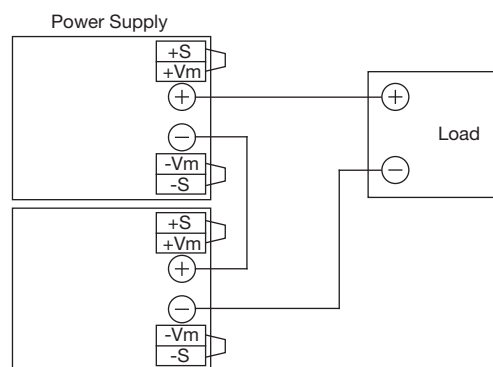

Method (B)

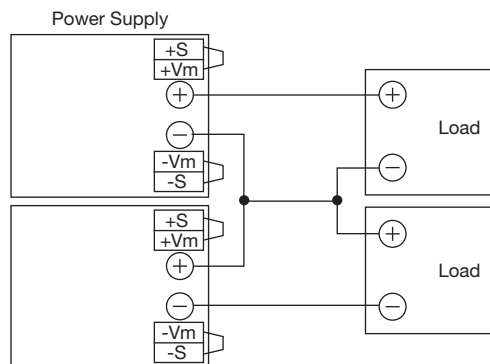

11 Parallel Operation

Current balancing function is provided. Both operations mode (A) and (B) are possible.

(A) To Increase the Output Current

Correct PC to PC terminal and COM to COM terminal, the current balancing function activates and output current of each power supply is equivalently supplied to load. Wires to PC terminals, COM terminals shall be as short as possible and same length and twisted.

- (1) Adjust the output voltage of each power supply to be same value within 1% or 100mV whichever is smaller.
- (2) Use same length and type of wires for all load lines.
- (3) Please make sure that the sum of output current values does not exceed a value obtained from the right side of following equation.
Maximum of total output current in parallel operation ≤ Rated current per unit × Number of units × 0.9
- (4) Parallel operation is possible up to 5 units.

(B) To Use as a Backup Power Supply

- (1) Adjust the output voltage (Vo) of each power supply to be same value within 1% or 100mV whichever is smaller.
- (2) Set power supply output voltage higher to compensate the forward voltage drop of diode.
- (3) Use within the specifications for output voltage and output current.
- (4) When one of power supplies fails, the remaining non-failure power supplies continue to maintain the output. If one of the power supplies stop operating, the output voltage may

change about 400mV (3V, 5V), 5% (12V, 15V, 24V, 36V, 48V, 60V) in its transient response.

Method (A)

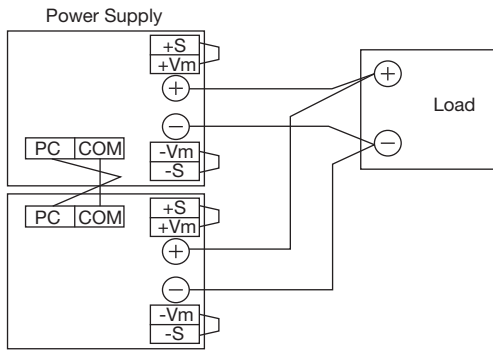

Method (B)

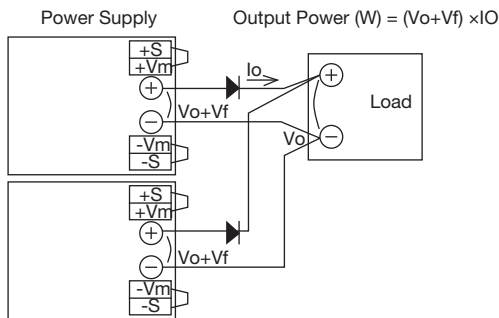

12 Isolation Test

Isolation resistance between output and ↓ (chassis) shall be more than 50MΩ at 500VDC and between output and AUX, CNT, ALM shall be more than 50MΩ at 100VDC. For safety operation, voltage setting of DC isolation tester must be done before the test. Ensure that it is fully discharged after the test.

Output - FG (chassis) : 500VDC 50MΩ or more

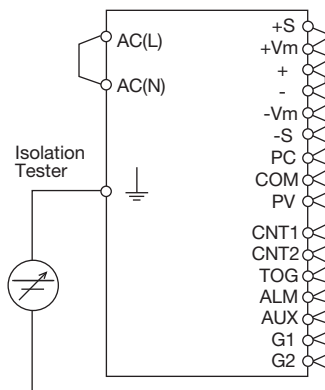

Output - CNT·AUX·ALM : 100VDC 50MΩ or more

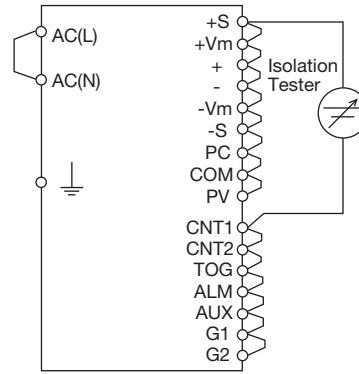

13 Withstand Voltage

SWS600L is designed to withstand 3.0kVAC, SWS1000L is designed to withstand 4.0kVAC between input and output. This series is designed to withstand 2.0kVAC between input and ↓ (chassis), 500VAC between output and ↓ (chassis), and 100VAC between output and CNT, AUX, ALM terminal each for 1 minute. When testing withstand voltage, set current limit of withstand voltage test equipment at 20mA.

(Output - ↓ (chassis) and Output - Control : 100mA).

The applied voltage must be gradually increased from zero to testing value and then gradually decreased for shut down. When timer is used, the power supply may be damaged by high impulse voltage at timer switch on and off. Connect input and output as follows.

Input - Output (dotted line) : 3.0kVAC 1min. (20mA),
(SWS1000L: 4.0kVAC 1min 20mA)

Input - ↓(chassis) (solid line) : 2.0kVAC 1min. (20mA)

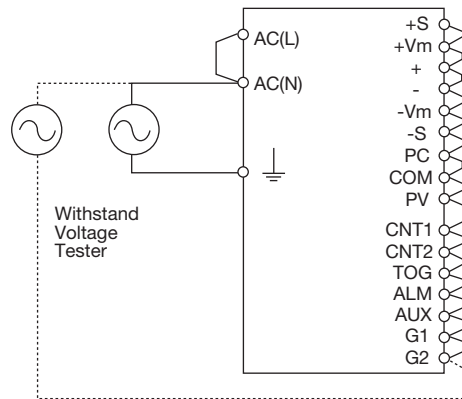

Output - ↓ (chassis) : 500VAC 1min. (100mA),
(SWS600L-60: 651VAC 1min 130mA)

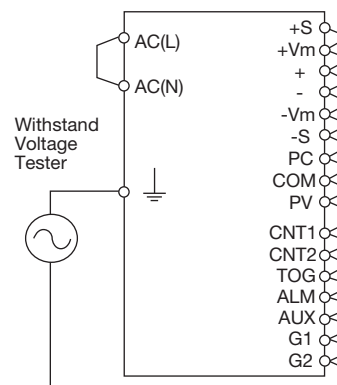

Output - CNT·AUX·ALM : 100VAC 1min. (100mA)

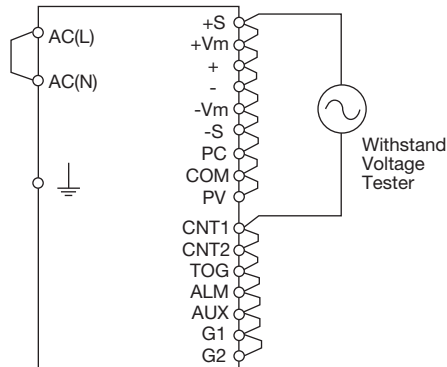

14 Output Voltage External Control (PV)

Output voltage external control function is available. Output voltage can be varied by applying an external voltage (1-6V) to "PV" terminal and "COM" terminal. Please consider the following characteristics.

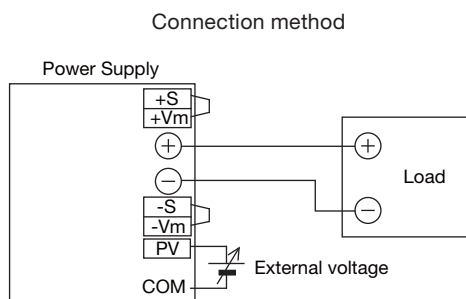

Output Voltage Linearity

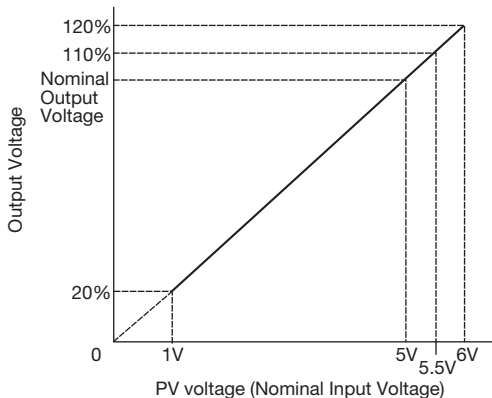

Output Voltage Derating

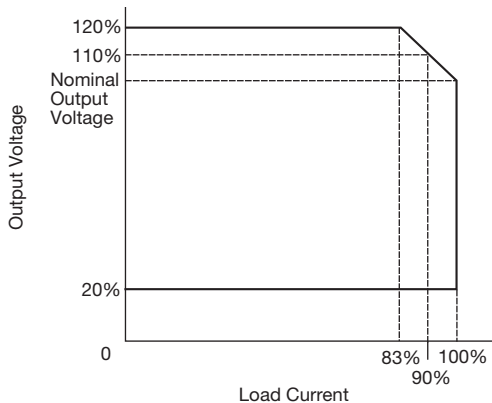

Note 1. Regarding output voltage adjustment below 20%, please consult our sales.

Note 2. For 3.3V output model, limit output voltage variation range at 30% - 120%. At PV voltage variation 1.5V - 6V.
 For 15V output model, limit output voltage variation range at 20% - 130%. At PV voltage variation 1V - 6.5V.
 For 48V output model, limit output voltage variation range at 20% - 116.7%. At PV voltage variation 1V - 5.8V.
 For 60V output model, limit output voltage variation range at 20% - 110%. At PV voltage variation 1V - 5.5V.

15 Output Peak Current

For 24V, 48V output model, please meet the following conditions. Reduce peak current value according to output derating as section 4-2.

Input voltage range : AC170V - 265V

Continuous Peak output time (τ) : Within 10 seconds

Peak output current (I_p) : Within the rated peak output current

Average DC output current (I_m) : Within the rated output current, I_{av}

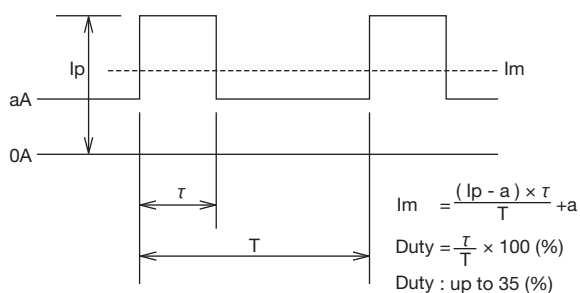

I_p : Peak output current (A)

I_{av} : Rated output current (A)

I_m : Average output current (A)

τ : Peak current pulse width (sec)

T : Period (sec)

16 Auxiliary Supply

Auxiliary supply (12V, 0.1A max) is provided to ease customer application. Aux voltage is functionally isolated from all other signal terminals and output terminals, and it is always available as long as input power in the specified voltage range is present.

5. Mounting Directions

1 Mounting Directions

Recommended standard mounting method is (A). Method (B) and (C) are also possible. Refer to the derating below.

SWS600L

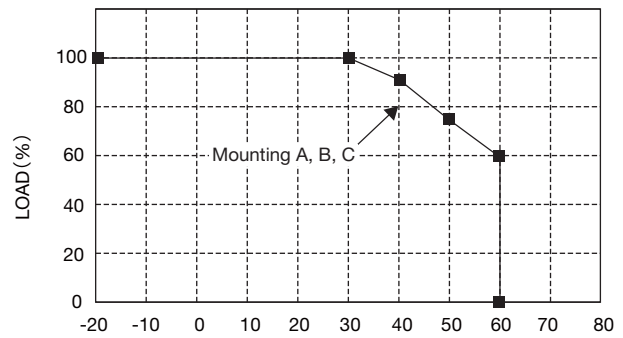
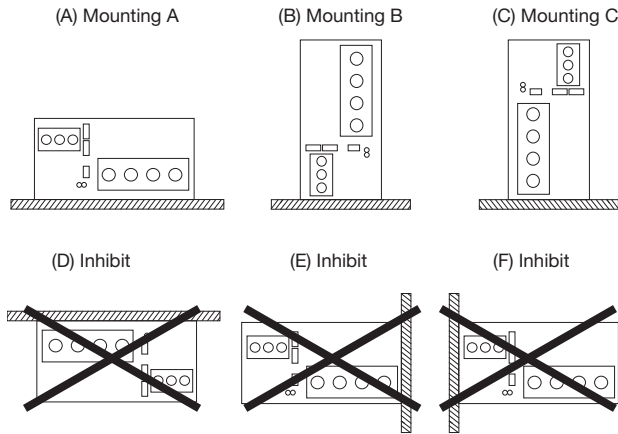

Ta (°C)	Load (%) Mounting A, B, C
-20 to +30	100
+40	90
+50	75
+60	60

*Output derating for SWSS600L/RF Models.

SWS1000L

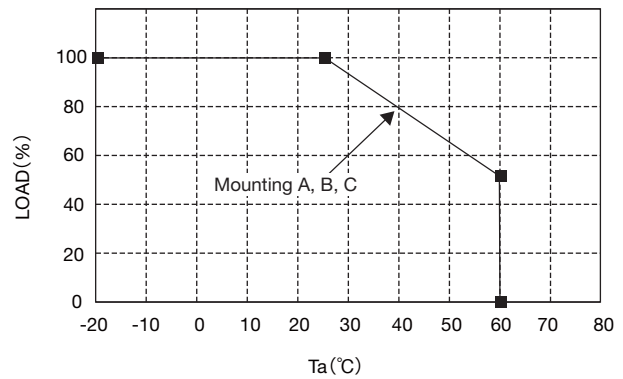
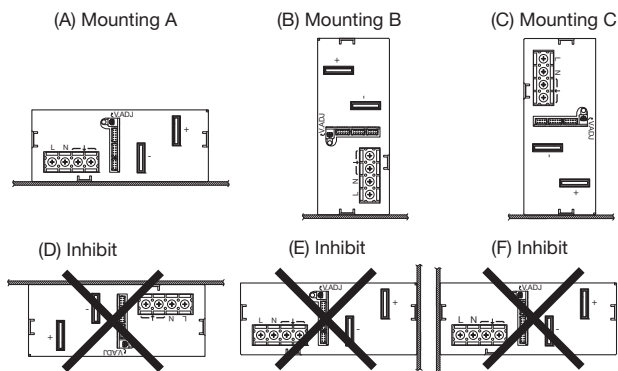

Ta (°C)	Load (%) Mounting A, B, C
-20 to +25	100
+60	50

*Output derating for SWS1000L/RF Models.

2 Output Derating

OUTPUT DERATING CURVE

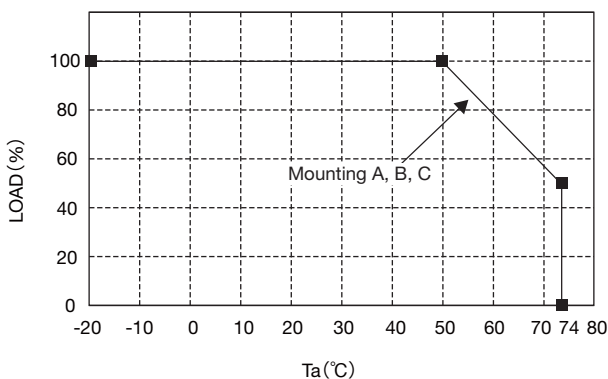

Ta (°C)	Load (%) Mounting A, B, C
-20 to +50	100
+74	50

*Output derating for both SWSS600L and SWS1000L

3 Mounting Method

- Forced air cooling type power supply.
This power supply has ventilating holes on the front and back side panels. Keep these two areas freely as much as possible.
- The maximum allowable penetration for screw is 6mm.
Incomplete thread of mounting screw should not be penetrated.
- Recommended torque for mounting screw : M4 screw : 1.27 N · m (13.0kgf · cm)

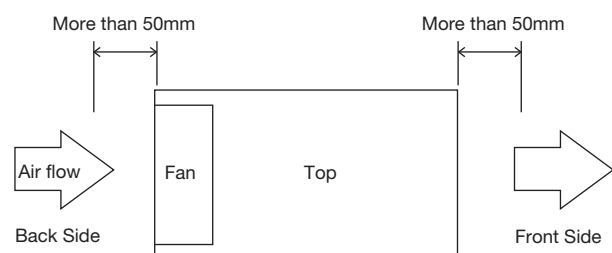

6. Wiring Method

- (1) The output load line and input line shall be separated to improve noise sensitivity.
- (2) The sensing lines shall be twisted and separated from the output lines for remote sensing.
- (3) Use all lines as thick and short as possible to make lower impedance, clamping core at both input and output wires benefit EMI performance.
- (4) Attaching a capacitor to the load terminals can eliminate noise.
- (5) For safety and EMI considerations, connect ↓ terminal to the mounting set ground terminal, power supply and load mounting on aluminum plate is recommended for EMI setting.
- (6) Recommended torque for the terminal :

SWS600L Input terminal (M4 screw)	: 1.27 N · m (13.0kgf · cm)
Output terminal (M5 screw)	: 2.5 N · m (25.5kgf · cm)
SWS1000L Input terminal (M4 screw)	: 1.27 N · m (13.0kgf · cm)
Output terminal (M8 bolt & nut)	: 10.8 N · m (110kgf · cm)
(M4 screw)	: 1.27 N · m (13.0kgf · cm)

[The PHD connector manufacture method]

This product is using SPHD-001T-P0.5 or SPHD-002T-P0.5 connector made from JAPAN SOLDERLESS TERMINAL MFG CO LTD. Regarding to manufacture of a connector, it becomes the regulation as following.

a). Applicable Wire and Crimping tool

Wire size is AWG#26 - AWG#22 and insulation outer dia is ϕ 1.0 - ϕ 1.5 mm.

Appreciable wire per barrel size is UL1007 (standard wire) and its equivalent standard wire can be used. Regarding the AWG#22, use UL1061 or its equivalent standard wire, because wire insulation outer diameter of UL1061 is small.

Crimping tool is as below.

Crimping tool	Crimping applicator	Dies
AP-K2 or AP-KS	MKS-LS-10 or MKS-L-10	SPHD-001-05/SPHD-002-05

b). Crimping Operation

The reference value of wire strip is 2.3mm. As wire strip length differs depending on type of wire and crimping method, decide the best wire strip length considering processing condition. When wire is stripped, do not damage or cut off wire conductors.

Table of crimp height

SPHD-001T-P0.5

Wire		Insulation O.D (mm)	Crimp height (mm)	
Type	Size		Conductor part	Insulation part
UL1007	AWG #26	1.3	0.60 - 0.70	1.7
UL1007	AWG #24	1.5	0.65 - 0.75	1.8
UL1061	AWG #22	1.4	0.70 - 0.80	1.8

SPHD-002T-P0.5

Wire		Insulation O.D (mm)	Crimp height (mm)	
Type	Size		Conductor part	Insulation part
UL1007	AWG #28	1.2	0.55 - 0.60	1.6
UL1007	AWG #26	1.3	0.60 - 0.65	1.7
UL1007	AWG #24	1.5	0.62 - 0.67	1.8

Note1. Crimp height at wire barrel should be set to pre-determined dimensions.

Note2. Adjust crimp height at wire insulation barrel to the extent that wire insulation is slightly pressed, and set it so that crimping is not excessivary.

Note3. Crimping condition at wire insulation barrel is as below Fig.1.

Note4. For AWG#28, #26, #24, use UL1007 type. For AWG#22, use UL1061 type.



Fig.1

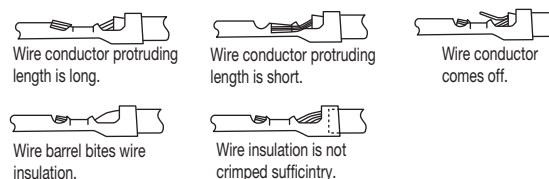

Fig.2: Examples of defective crimping

Check of crimping appearance visually for correct crimping as referring to above Fig.2. Check the tensile strength at crimped part when operation finishes.

Table of tensile strength at crimped part.

SPHD-001T-P0.5

Wire size	Requirement N min.	Actual value N
UL1007 AWG#26	20	39.2 - 45.1
UL1007 AWG#24	30	68.6 - 74.5
UL1007 AWG#22	40	92.1 - 96.0

SPHD-002T-P0.5

Wire size	Requirement N min.	Actual value N
UL1007 AWG#28	15	27.0 - 34.3
UL1007 AWG#26	20	44.1 - 48.0
UL1007 AWG#24	30	66.6 - 71.5

c). Inserting contact into housing

Inserting crimped contact into housing

- (1) Do not apply any pulling force to crimped part, and insert contact parallel to housing.
- (2) Insert contact into housing without stopping to innermost.
- (3) Check secure locking per each insertion by pulling wire softly in order to check that contact does not come off housing. Besides, check whether there is the backlash in the direction of insertion axis.

Defect example of slation insertion

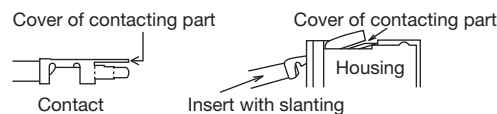

d). Mating and Unmating Connector

- (1) Inserting connector
Hold receptacle housing securely and insert into header straight against to header post until click sounds.
- (2) Unmating connector
Hold all wires securely and fix receptacle housing by fingers so as to pry, and then, withdraw it on the mating axis.

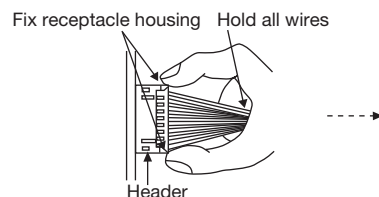

e). Routing of Wire

Routing wire so as not to apply external force to connector except force to such an extent that wire slightly buckles, considering an enough length to route and fixing of wire.

7. External Fuse Rating

Refer to the following fuse rating when selecting the external fuses that are to be used on input line. Surge current flows when line turns on. Use slow-blow or time-lag type fuse, not fast-blow fuse. Fuse rating is specified by in-rush current value at line turn-on. Do not select the fuse according to input current (RMS.) values under the actual load condition.

SWS600L : 15A SWS1000L : 20A

8. Fan life expectancy

The Fan-life has limitation. Therefore, periodic maintenance by exchanging the life-expired fan is required for the power supply. The following figure shows the life of fan.

Fan acoustic noise:

SWS600L, SWS1000L: build in fan speed control circuit .
 SWS600L : 45dB[A] at room temperature, 50dB[A] at high ambient temperature.
 SWS1000L: 53dB[A] at room temperature, 55dB[A] at high ambient temperature
 SWS600L/RF: 50dB[A]

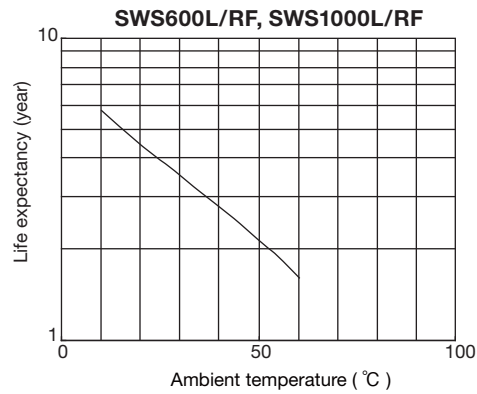
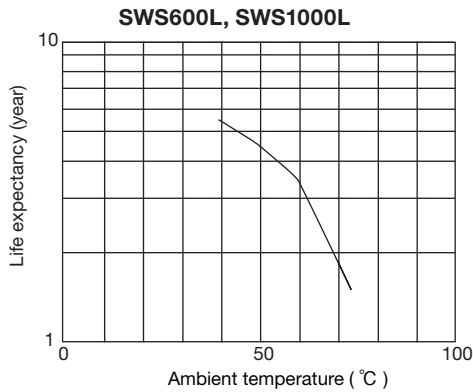

9. Special instructions for IEC/EN/UL/CSA 60601-1 (SWS1000L only)

- (1) These products are designed for continuous operation within an overall enclosure, and must be mounted such that access to the mains terminals is restricted. See Clause 16, IEC/EN/UL60601-1.
- (2) These products are NOT suitable for use in the presence of flammable anaesthetic mixtures with air or with oxygen or nitrous oxide.
- (3) These products are classed as ordinary equipment according to IEC/EN/UL60601-1 and are NOT protected against the ingress of water.
- (4) Connect only apparatus complying with IEC/EN/UL60601-1 to the signal ports.
- (5) Except for permanently installed equipment as defined in Clause 57.6 of IEC/EN/UL60601-1 the overall equipment in which these products are installed must have double pole fusing on the input mains supply. The products themselves have single pole fusing in the live line.
- (6) When the PSU is installed within medical equipment an all pole mains input disconnect device must be fitted.
- (7) Reference should be made to local regulations concerning the disposal of these products at the end of their useful life.
- (8) These products have not been assessed to IEC/EN60601-1-2 (EMC) but EMC test data is available from NEMIC-LAMBDA (S) PTE LTD.

10. Before concluding that the unit is at fault

Before concluding that the unit is at fault, make the following checks.

- (1) Check if the rated input voltage is connected.
 - (2) Check if the wiring of input and output is correct.
 - (3) Check if the I/O terminal connection is properly tighten by regulated torque.
 - (4) Check if the wire thickness is enough.
 - (5) Check if the output voltage control (V.adj) is properly adjusted. OVP might be triggered and output is shut down.
 - (6) If use function of the Remote ON/OFF control, check if the Remote ON/OFF control is properly used.
 - (7) Check if the built-in FAN is not stopped. Is FAN stopped by something irregular or etc?
- If FAN stops, the ALM signal turn "High" level and OTP might be activated.
- (8) Power supply has ventilating holes on the front and back panels. Check if there is any irregulars or dust, etc.
 - (9) Is the chassis of power supply hot abnormally? The output is shut down by OTP operation. Please re-input after the unit is cooled down sufficiently.
 - (10) Check if the output current and output power does not over specification.
 - (11) Audible noise can be heard when input voltage waveform is not sinusoidal.
 - (12) Audible noise can be heard during dynamic load operation.