



Features:

- Safety meet ITE and Medical application
- Built-in active PFC for power > 75W
- Built-in power on LED indicator
- Easy plug for remote sense input
- Power up 8000uF capacitance capability
- With all necessary protection
- Efficiency up to 85%
- 1U height

Applications:

- For medical and industrial machinery.
- For industrial equipment.

General Specifications:

Input voltage90VAC to 264VAC
 Input frequency..... 47Hz to 63Hz
 Inrush current < 30A at 115VAC
 (cold start at 25°C) or < 60A at 230VAC
 Capacitive load up to 8000uF
 Efficiency 85% typical
 at rated load and 115VAC
 Hold up time > 20ms
 at rated load and 115VAC
 Over load protection auto recovery
 Over temperature protection auto recovery
 Short circuit protection auto recovery

Over voltage protection latch off
 Remote sense available
 Power on indicator green LED on board
 Operating temperature 0°C to 70°C ambient
 start up from -20°C, derate output 2.5%/°C from 50°C
 SNP-B30X derated from 40°C by 1.5%/°C
 Storage temperature-20°C to +85°C
 Operating humidity5% to 95% non-condensing at 50°C
 EMIFCC docket 20780 curve "B", EN55022 curve "B"
 EMS EN61000-4-2,-3,-4,-5,-6,-11
 Safety meet UL 60950-1, UL 60601-1
 CSA C22.2 No. 60950-1 & 60601-1
 EN 60950-1, 60601-1

Mechanical Specifications:

SNP-B04 Series (3.35"x3.94"x1.38")

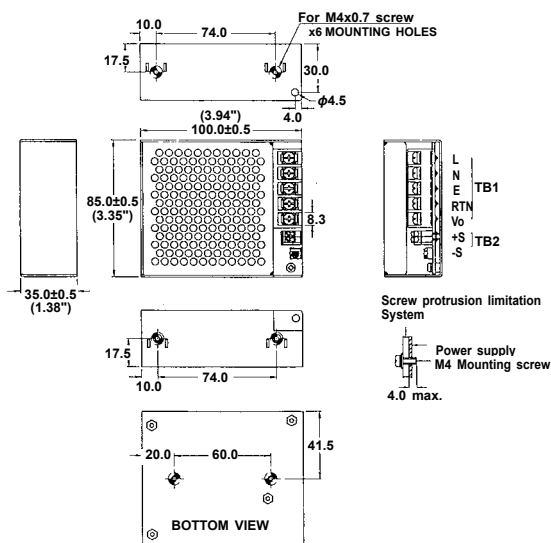

SNP-B06 Series (3.35"x5.12"x1.38")

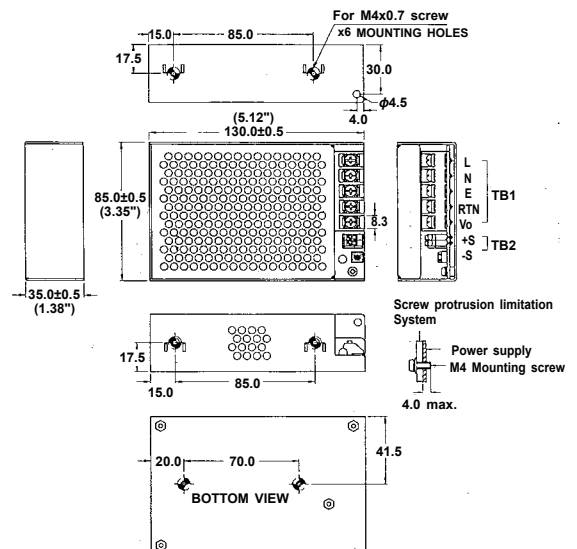

-Eric-

10 years Warranty (contact Skynet's Distributors for details)

SNP-B10 Series (3.35"x6.3"x1.38")

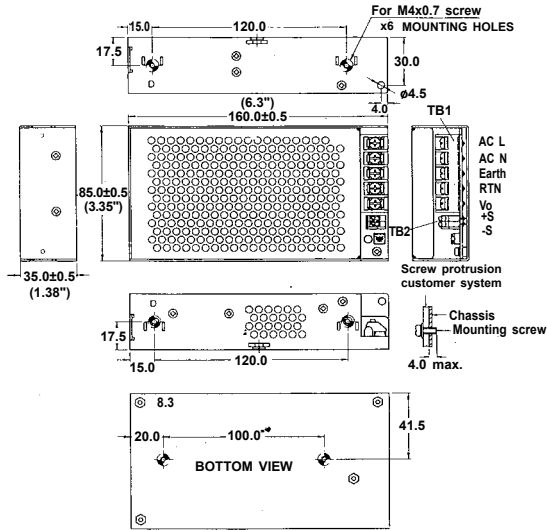

SNP-B15 Series (3.94"x7.48"x1.61")

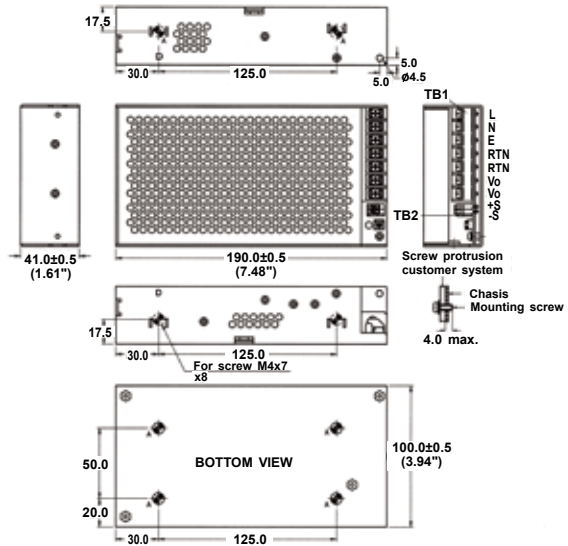

SNP-B20 Series (3.94"x8.27"x1.65")

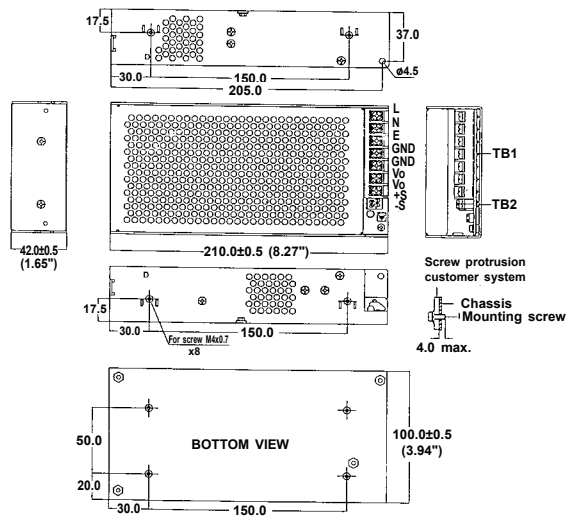

SNP-B30 Series (3.94"x9.06"x1.65")

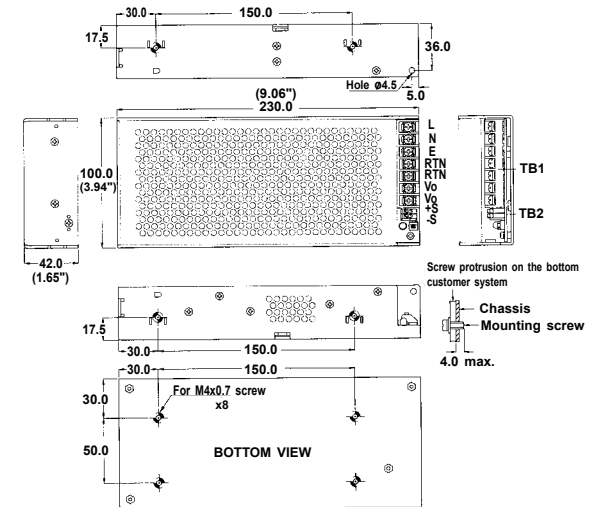

Notes:

- Size:
 - SNP-B04x : 3.35" x 3.94" x 1.38" / 85 x 100 x 35 (mm)
 - SNP-B06x : 3.35" x 5.12" x 1.38" / 85 x 130 x 35 (mm)
 - SNP-B10x : 3.35" x 6.30" x 1.38" / 85 x 160 x 35 (mm)
 - SNP-B15x : 3.94" x 7.48" x 1.61" / 100 x 190 x 41 (mm)
 - SNP-B20x : 3.94" x 8.27" x 1.65" / 100 x 210 x 42 (mm)
 - SNP-B30x : 3.94" x 9.06" x 1.65" / 100 x 230 x 42 (mm)
- Power derating curve:
 - For SNP-B04x: Net weight: 280 g approx. / unit; Gross weight: 14.8 kg approx. / carton, 40 units / carton; Carton size (mm): 578 (L) x 366 (W) x 271 (H)
 - For SNP-B06x: Net weight: 345 g approx. / unit; Gross weight: 14.8 kg approx. / carton, 32 units / carton; Carton size (mm): 541 (L) x 392 (W) x 271 (H)
 - For SNP-B10x: Net weight: 510 g approx. / unit; Gross weight: 13.2 kg approx. / carton, 20 units / carton; Carton size (mm): 458 (L) x 360 (W) x 264 (H)
 - For SNP-B15x: Net weight: 645 g approx. / unit; Gross weight: 16.7 kg approx. / carton, 20 units / carton; Carton size (mm): 512 (L) x 376 (W) x 295 (H)
- Packing:
 - For SNP-B04x: Net weight: 280 g approx. / unit; Gross weight: 14.8 kg approx. / carton, 40 units / carton; Carton size (mm): 578 (L) x 366 (W) x 271 (H)
 - For SNP-B06x: Net weight: 345 g approx. / unit; Gross weight: 14.8 kg approx. / carton, 32 units / carton; Carton size (mm): 541 (L) x 392 (W) x 271 (H)
 - For SNP-B10x: Net weight: 510 g approx. / unit; Gross weight: 13.2 kg approx. / carton, 20 units / carton; Carton size (mm): 458 (L) x 360 (W) x 264 (H)
 - For SNP-B15x: Net weight: 645 g approx. / unit; Gross weight: 16.7 kg approx. / carton, 20 units / carton; Carton size (mm): 512 (L) x 376 (W) x 295 (H)

- For SNP-B20x: Net weight: 750 g approx. / unit; Gross weight: 12.6 kg approx. / carton, 14 units / carton; Carton size (mm): 527 (L) x 322 (W) x 294 (H)
- For SNP-B30x: Net weight: 1000 g approx. / unit; Gross weight: 13 kg approx. / carton, 10 units / carton; Carton size (mm): 396 (L) x 341 (W) x 295 (H)

4. Din Rail Mounting Fixture:

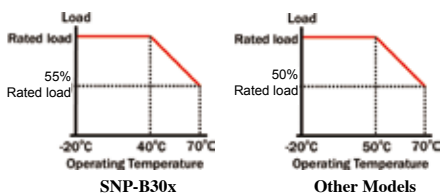
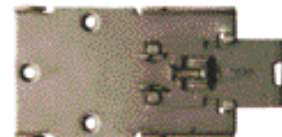

Output Specifications:

MODEL NO.	OUTPUT RAIL	LOAD				VOLTAGE ACCURACY	RIPPLE NOISE	LINE REG.	LOAD REG.
		MIN.	RATED	MAX.	PEAK				
SNP-B045	+18V	0A	2.2A		4.2A	±2%	50mVpp	±1%	±1%
SNP-B047	+12V	0A	3.3A		6A	±2%	50mVpp	±1%	±1%
SNP-B048	+15V	0A	2.7A		5A	±2%	50mVpp	±1%	±1%
SNP-B049	+24V	0A	1.7A		3A	±2%	50mVpp	±1%	±1%
SNP-B065	+18V	0A	3.3A		6.7A	±2%	50mVpp	±1%	±1%
SNP-B067	+12V	0A	5A		8.5A	±2%	50mVpp	±1%	±1%
SNP-B068	+15V	0A	4A		6.5A	±2%	50mVpp	±1%	±1%
SNP-B069	+24V	0A	2.5A		5A	±2%	50mVpp	±1%	±1%
SNP-B105	+18V	0A	5.6A		8A	±2%	50mVpp	±1%	±1%
SNP-B107	+12V	0A	8.3A		12A	±2%	50mVpp	±1%	±1%
SNP-B108	+15V	0A	6.7A		10A	±2%	50mVpp	±1%	±1%
SNP-B109	+24V	0A	4.2A		6A	±2%	50mVpp	±1%	±1%
SNP-B155	+18V	0A	8.3A		10.7A	±2%	50mVpp	±1%	±1%
SNP-B157	+12V	0A	12.5A		16A	±2%	50mVpp	±1%	±1%
SNP-B158	+15V	0A	10A		13A	±2%	50mVpp	±1%	±1%
SNP-B159	+24V	0A	6.5A		8A	±2%	50mVpp	±1%	±1%
SNP-B205	+18V	0A	11A		16.5A	±2%	50mVpp	±1%	±1%
SNP-B207	+12V	0A	16.7A		25A	±2%	50mVpp	±1%	±1%
SNP-B208	+15V	0A	13.3A		20A	±2%	50mVpp	±1%	±1%
SNP-B209	+24V	0A	8.3A		10A	±2%	50mVpp	±1%	±1%
SNP-B305	+18V	0A	16.7A		26.7A	±2%	100mVpp	±1%	±1%
SNP-B307	+12V	0A	23A		37.44A	±2%	100mVpp	±1%	±1%
SNP-B308	+15V	0A	18.5A		32A	±2%	100mVpp	±1%	±1%
SNP-B309	+24V	0A	11.66A		15A	±2%	50mVpp	±1%	±1%

Note:

1. All the measurements are taken at rated load and nominal line unless specified.
2. The output voltage is set in production line within the voltage accuracy range at 60% rated load, nominal line. Other voltage accuracy can be done upon requested.
3. The output can deliver listed peak load for more than 10 seconds.
4. Ripple & noise is measured by oscilloscope with 20MHz bandwidth limited and terminated the load with 0.47uF capacitor.
5. Line regulation is defined by changing ±10% of input voltage from nominal line at rated load.
6. Load regulation is defined by changing ±40% of load from 60% rated load at nominal line.
7. Hold up time is measured from the end of the last charging pulse to the time which the output drop down to the regulation limit.

-Eric-

Performance for SNP-B049:

1. Output turn on wave form

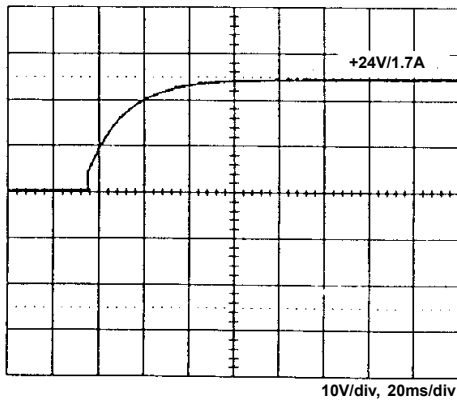

2. Output turn off wave form

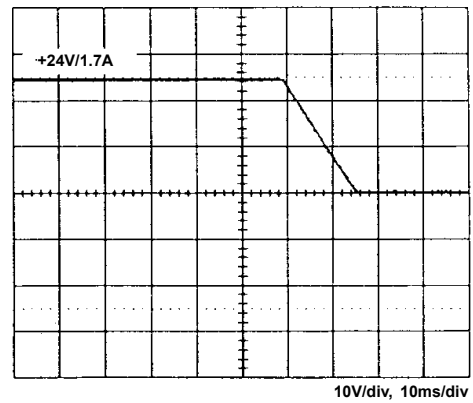

3. Hold-up time

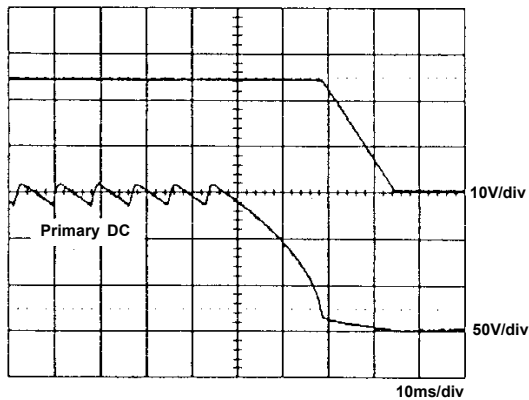

4. Over voltage protection

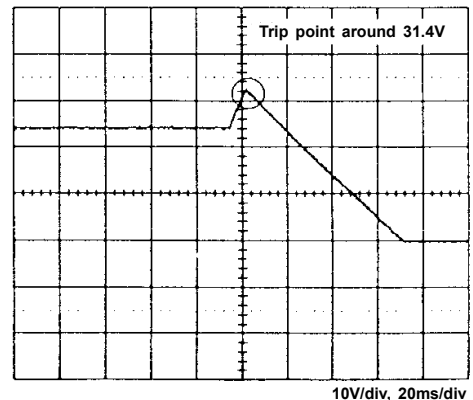

5. FCC B

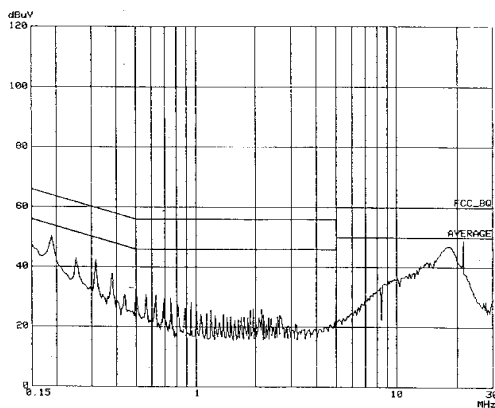

6. EN 55022 B

